

Totally Trebuchet Construction Guide

An Illustrated Assembly Manual

Introduction

Medieval engineers designed and built trebuchets capable of accurately hurling large masses over distances spanning hundreds of feet. The GEARS-IDS™ trebuchet lacks the power of the historic siege engines, but the precision and accuracy of these mechanical models are just as impressive, and they are much safer to operate within school classrooms and foyers!

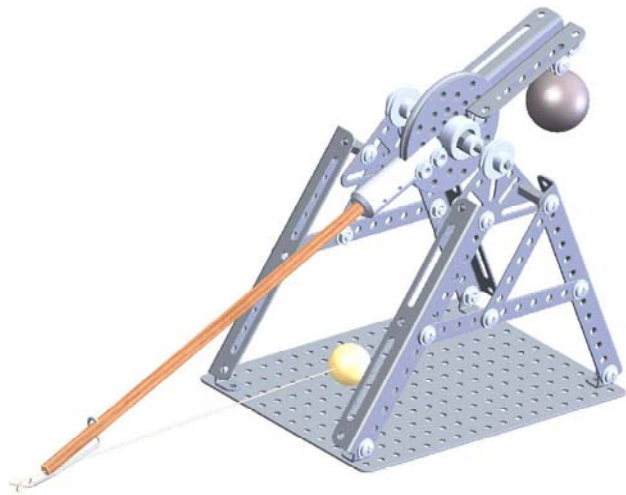

Designing and building trebuchet models for use in engineering activities is an excellent way to develop skills and competencies in science, engineering and mathematics.

Totally Trebuchet builders need to carefully consider the 8 design parameters that affect the trebuchet's performance.

The trebuchet is a design problem with multiple solutions. It is a wonderful opportunity to apply the iterative process of experimenting, building, modifying and testing design decisions. This process results in the creation of a data base of engineering knowledge and experience used to

incrementally improve the trebuchet's performance.

Design parameters refer to the variable trebuchet lengths and masses that can be changed in an effort to optimize the performance of the machine with respect to hurling (*Throwing*) distance and efficiency

8 Design Parameters

Lengths

- I1 Counter Weight Arm Length (Short Arm)
- I2 Throwing Arm Length (Long Arm)
- I3 Projectile Sling Length
- I4 Counter Weight Hangar Length
- I5 Axle to Base Height

Masses

- m1 Counter Weight Mass
- m2 Projectile Mass
- mb Beam Mass

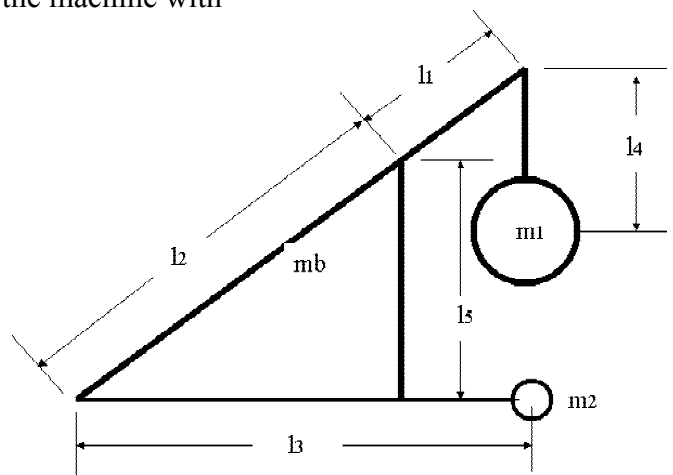

Sketching Exercise: Sketch this trebuchet schematic and label the 8 design parameters. Use this sketch to record changes you make as you operate, test and improve the performance of your working trebuchet model

Build a Data Base of Knowledge and Experience

Before beginning any project, it helps to have a sense of what the beginning, middle and end of the project might look like. It also helps to become familiar with the look, feel and identification of the parts. For best results, read through this document and identify the parts prior to building the trebuchet.

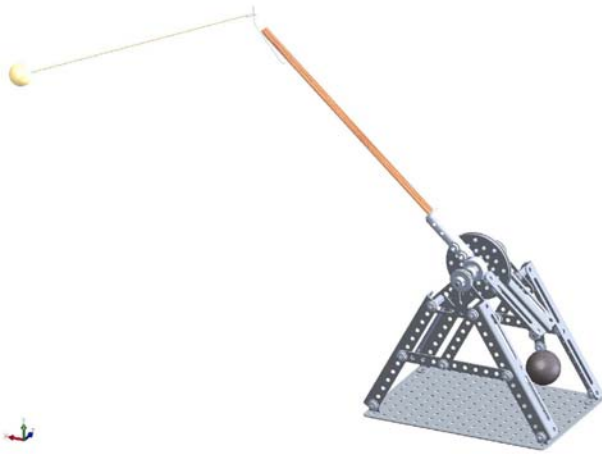

Note: A team of 2 or 3 people can build the Trebuchet quickly and efficiently. Each team member can assume construction responsibility for one of four subassemblies from which the trebuchet is constructed. (2 frames, 1 lever arm assembly and 1 projectile assembly.)

Performance Tip. Engineering is a team sport. Be an engineering MVP. Accept and commit to completing specific responsibilities. Always remember to return the tools and parts to their appropriate storage containers.

Build-Test-Modify: A Description of The Trebuchet Activity

1. Obtain and organize the necessary tools and materials (*Listed below*)
2. Complete a cursory review of this document to learn what needs to be done and what will be needed to do it.
3. Create a trebuchet construction team and assign responsibilities for constructing the three major subassemblies.
4. Build the subassemblies and integrate them into a working trebuchet.
5. Measure and record the design parameters of the trebuchet you build. These include sling lengths, counter weight arm lengths, launch angles, throwing arm lengths, axle heights, counterweight masses, projectile masses and beam mass. Make a sketch that clearly illustrates the dimensions and components of your trebuchet model.
6. Use the GEARS-TrebStar trebuchet simulator to create multiple design iterations and optimize the dimensions and values of the trebuchet parameters.
7. Practice using the trebuchet and refine the range and accuracy through iterative changes and testing.
8. Obtain and read the Totally Trebuchet Engineering Challenge rules and description.

Note: The GEARS-IDS™ Totally Trebuchet kit includes the components needed to modify the values or dimensions of all 8 of the listed design parameters. However, we strongly suggest that the Totally Trebuchet games and activities all be played using only the 12 oz. counterweight included in the kit.

Caution: The sling release mechanism on the end of the throwing arm is a sharp pointed device. Both the throwing arm and the projectile are highly energized and fast moving. This makes them dangerous and capable of causing eye injury. To protect against eye injuries- Always wear safety glasses when working on, testing or using trebuchet models.

Organize the Tools and Materials

The trebuchet can be assembled with minimal frustration by taking the time to read through the directions. Prepare the necessary tools and materials before beginning the assembly.

Required Tools

Safety Glasses	5/64, 5/32, 1/8 Allen Wrenches or Hex Keys
#2 Phillips Head Screwdriver	Dial Calipers
5/16" Combination Wrench	25' – 100' Tape Measures
3/8" Combination Wrench	12" Rule
Needle nose pliers	

Materials

Refer to the end of this text for an illustrated parts catalog.

Structural Metal Components

Qty.	
1	6x9 Flat Plate
4	13 Hole Angles
2	7 Hole Angles
2	11 Hole Flat Bars
2	7 Hole Flat Bars
2	Sine Triangles
4	90 Degree Fish Plates
1	180 Degree Fish Plate

Hardware

Qty.	
50	#10-24 x 1/2" PH Machine Screws
6	#10-24 x 3/4 PH Machine Screws
50	#10-24 Nuts
100	#10 Flat Washers
50	#10 Split Ring Lock Washers
10	#10 Fender Washers
4	#10-24 x 1" PH Machine Screws
2	#6-32 x 1/2" ph machine Screw
4	#6 Flat Washers
2	#6 Hex Nuts

Machined Parts

Qty.	
1	3" Hex Wheel
1	4" x 3/16 Axle
1	1-1/2" x 3/16 Axle
1	7/16" x 3/16" bore Hex Adapter
1	1/2" Shaft Collar
6	3/16" Shaft Collars
1	Mast Holder and 2-#10-24 set screws

Miscellaneous Supplies and Materials

Qty.	
1	12 Ounce Lead Ball Fishing Weights
2	Wood Balls, 1" Diameter
2	Wood Balls 1-1/4" Diameter
2	Wood Balls 1-1/2" Diameter
10'	Fishing Line
1'	1/16" Welding Rod
2	18"x 5/16" Dowels
1	3/8" Hose Clamp

Performance Tip. Use flat washers whenever possible to evenly distribute the clamping force of the machine screw assemblies. Use split ring lock washers or nylon locking nuts to prevent machine screw fasteners from loosening during use.

Model Trebuchet Construction Illustrated

Support Frames

Step One: Attach 90 Degree Fish Plates

Necessary Components

Qty. Description

- 1 Rectangular 6 x 9 plate.
- 2 #10-24 Phillip head machine screws, nuts and washer assemblies.
- 2 90 degree fishplates

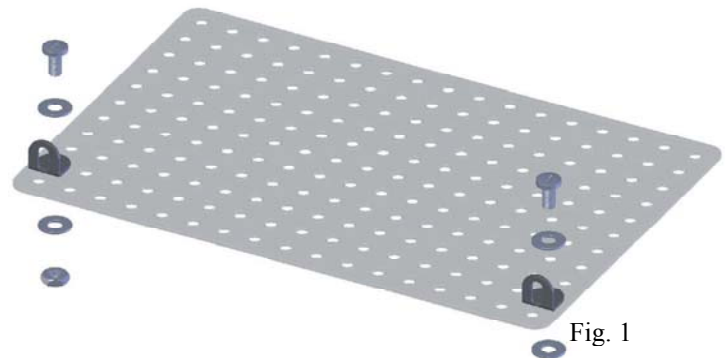

Fig. 1

Performance Tip. Lightly tighten all machine screws and nuts at this time. The fasteners can be fully tightened during final assembly.

Procedure

Use #10-24 x 3/8" Phillip head machine screws to attach the 90 degree fish plates to the end holes on the second row of the 6x9 base plate. Use split ring locking washers (*Not shown*) between all the hex nuts and flat washers. **The fishplate is secured to the end hole in the second row.**

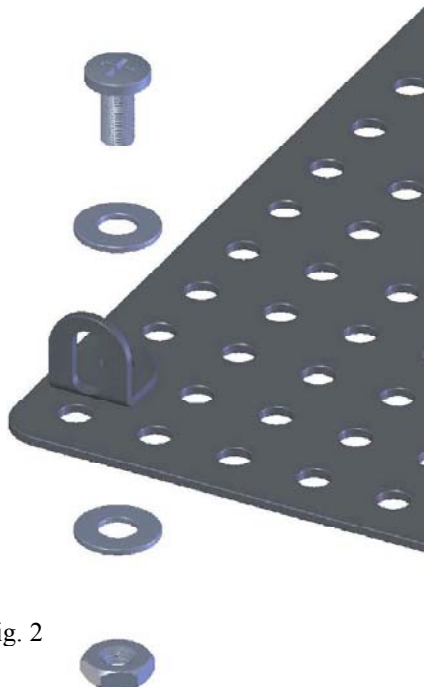

Fig. 2

Note: Be certain to align the orientation of the long hole in the 90 degree fish plate as illustrated in figure 2.

A Math Moment: Perimeter and Area

Make a sketch of the 6" x 9" Base Plate Use dial calipers to obtain the necessary dimensions. Using the information you collected, calculate the following:

- 1.) The perimeter of the 6"x 9" Base Plate.
- 2.) The surface area of (one) large side of the 6"x 9" Base Plate.
- 3.) The combined area of all the holes in the 6"x 9" Base Plate.
- 4.) The total surface area of aluminum. *Hint: This would include the 2 large sides, the outside edges and the inside edges of all the holes!*

Note: Perform all the calculations directly on the sketch and keep this work chronologically organized in your notebook.

For a complete explanation and answers to these problems refer to the Chapter 3.0 Trebuchet Math lessons dealing with 3.1.3-Perimeter, 3.1.4-Area and 3.1.5-Volume.

Support Frames *continued*

Step Two: Attach the 13 Hole Angles

Necessary Components

Qty. Description

- 2 13 hole angles
- 2 #10-24 x 1/2" Phillip head machine screws, nuts and washer assemblies.

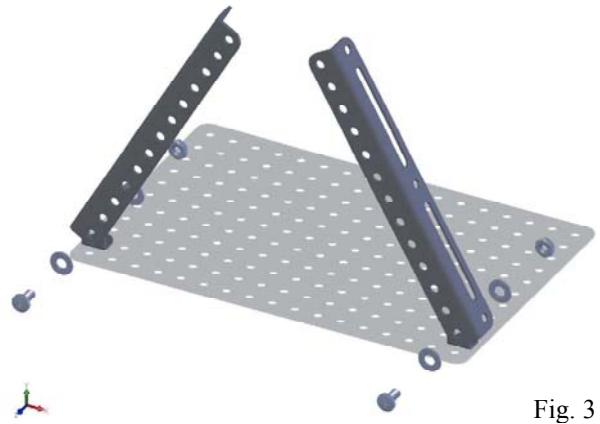

Fig. 3

Note: Flat washers are used with screws in order to evenly distribute the clamping force generated when the screw is tightened. See the *Science Second* below.

Procedure

Use #10-24 x 1/2" Phillip head machine screws to attach the 13 hole angles to the fish plates. Use split ring locking washers (*Not Shown*) between all the hex nuts and flat washers.

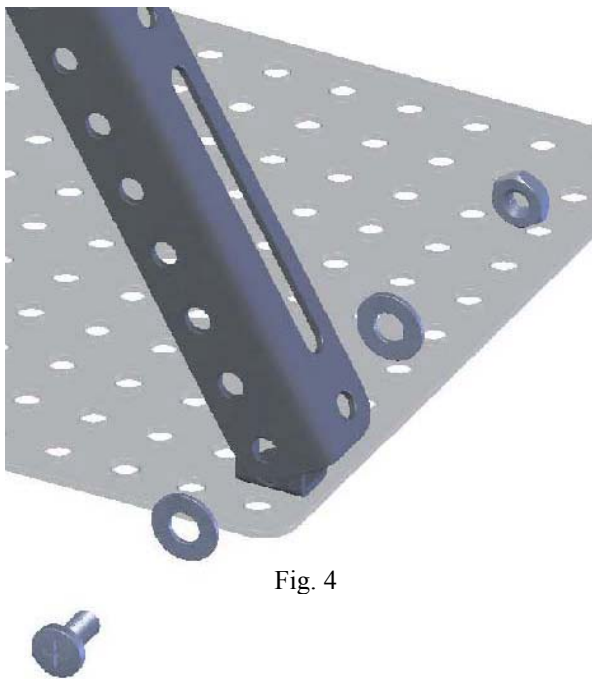

Fig. 4

Note: Be certain to align the orientation of the 13 hole angles as shown in figures 3 and 4. Mount the 13 hole angles outboard of the fish plates as illustrated.

Science Second

A machine screw is a simple machine. It can be described as an incline plane wrapped around a cylinder.

Find the Mechanical Advantage of the Screw

- 1.) Calculate the difference in height between two adjacent screw threads.

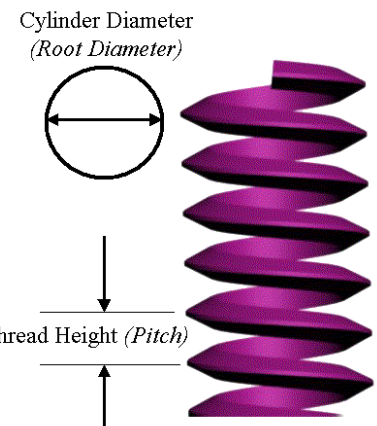

Fig. 5

- 2.) Divide by the circumference of the cylinder by the difference in height. This will yield an approximation of the theoretical mechanical advantage of the screw thread.

The information on the right indicates that a #10-24 Machine Screw creates a TMA (force multiplier) of 11- 12 times the applied force.

#10 –24 Machine Screw Specifications

- Root Diameter = 0.150" plus or minus.
- Root Circumference = 0.150 x 3.14 = 0.471"
- Thread Height/pitch = 1/24" or 0.041"

(TMA) Theoretical Mechanical Advantage

$$\text{TMA} = 0.471'' / 0.041'' = 11.48$$

Support Frames *continued*

Step Three: Attach the Cross Bracing

Obtain these components:

Qty. Description

- 1 11 hole flat bar
- 1 7 hole flat bar
- 3 #10-24 x 1/2" Phillip head machine screws, nuts and washer assemblies.
- 2 #10-24 coupling nut
- 2 #10-24 x 3/8" machine screw and washer

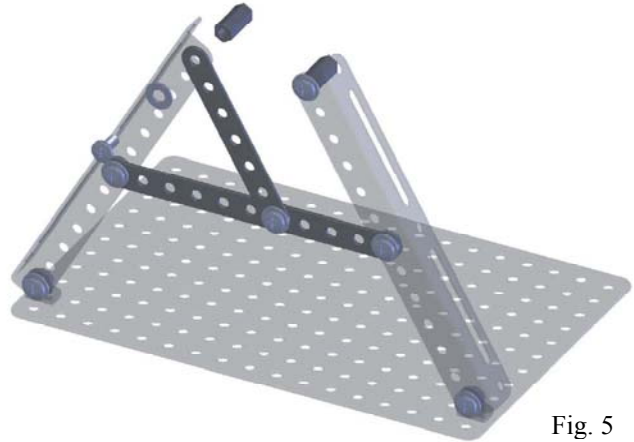

Fig. 5

Procedure

Use two #10-24 x 1/2" Phillip head machine screws to attach the 11 hole flat bar across the 13 hole angles.

Use one #10-24 x 1/2" Phillip head machine screws to attach the 7 hole flat bar diagonally across the 11 hole flat bar. Use one #10-24 x 3/8" machine screw and flat washer with a #10-24 coupling nut to attach the 7 hole flat bar to the right side 13 hole angle as shown in figure 5.

Fasten an additional #10-24 x 3/8" machine screw and flat washer with a #10-24 coupling nut to the left side 13 hole angle as shown in figure 5.

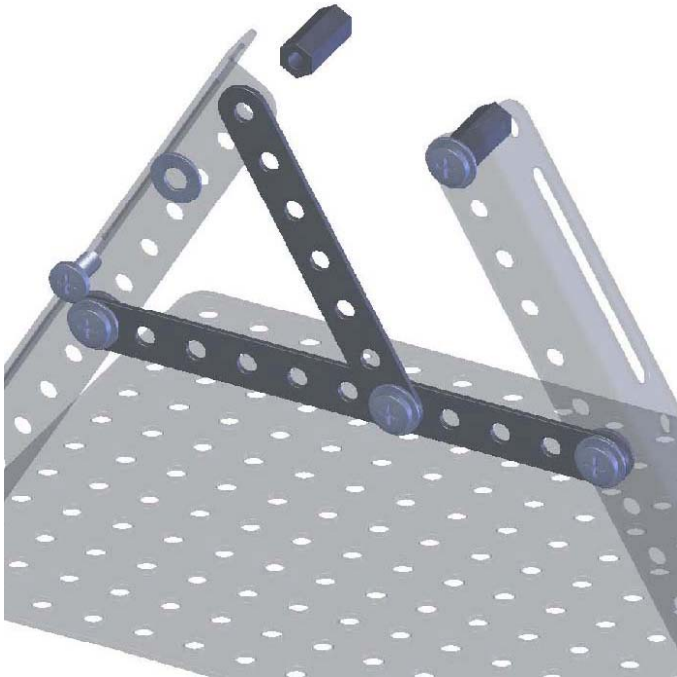

Note: Be careful to align the orientation of the 11 hole flat bar to the 13 hole angles as shown in figures 5 and 6. Mount the 7 hole flat bar diagonally as shown in figure 6. Attach the #10-24 coupling nuts to the end holes of the angles as shown in figure 6.

Fig. 6

Support Frames *continued*

Step Four: Attach the Sine Triangle

Obtain these components:

Qty. Description

- 1 Sine Triangle
- 2 #10-24 x 3/8" machine screw and washer

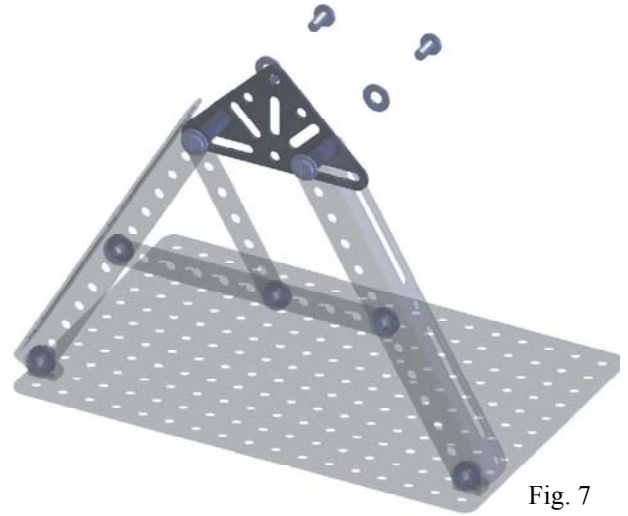
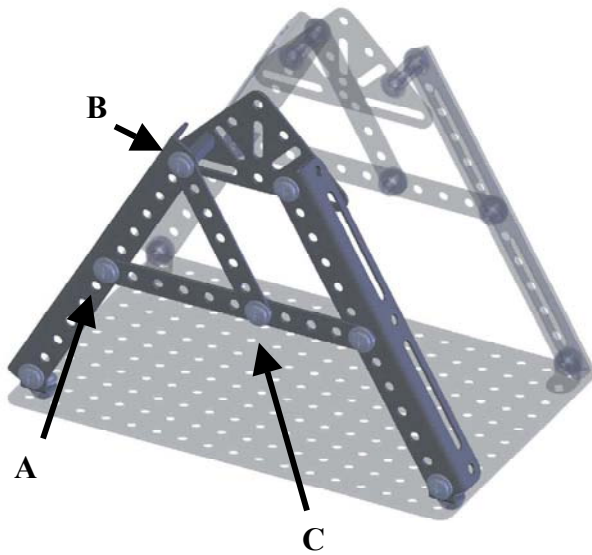

Fig. 7

Procedure

Use two #10-24 x 3/8" Phillip head machine screws and flat washers to attach the sine triangle to the coupling nuts as shown in figure 7.

Step Five: Repeat the Procedure for the Other Side



A Math Moment: Equilateral Triangles

The GEARS-IDS™ flat bars have 0.190" diameter holes drilled 0.50" on center. This means the center of each hole is $\frac{1}{2}$ " apart. The diagonal bracing of the trebuchet forms a triangle whose 3 sides are each 7 holes long! The three sides are the same length and they form an equilateral triangle. *Equi* means equal and *lateral* means side. This is an equal-sided triangle. See triangle ABC in fig 8.

Make a hand drawn sketch of the side view of the support frame and include all the dimensions needed to understand it's construction. Use this sketch and the paper it is drawn on to complete the following 5 exercises. Remember to keep copies of this work in your notebook.

1. Determine the measure of the angles of this equilateral triangle
2. What is the perimeter of this triangle?
3. Determine the approximate area of this triangle.
4. Make an accurate drawing of this triangle using a pencil, paper and a rule.
5. Measure and record a height of the triangle you drew.

Note: Use either or both millimeters or inch units for this exercise.

Throwing Arm Assembly

Step One: Make up the Axle Assembly (*figure 10*)

Necessary Components

Qty. Description

- 1 3/16" diameter x 4" long axle.
- 1 Stainless steel hex adapter.
- 6 3/16" (*bore*) shaft collars.
- 3 3/16" fender washers



Fig. 9

The completed throwing arm assembly

Procedure

Obtain the necessary components to construct the axle assembly illustrated in figure 10. Use only the hex adapter and set the remaining components aside for later use.

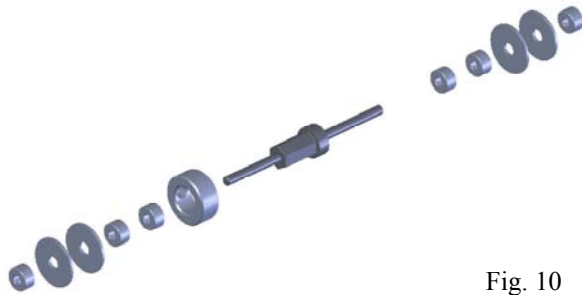

Fig. 10

Step Two: Secure the 3" Wheel and Hex Adapter (*Figure 11*)

Necessary Components

Qty. Description

- 1 Stainless steel hex adapter.
- 1 3" Wheel
- 1 1/2" (*bore*) Shaft Collar

Procedure

Fasten the 3" wheel to the hex adapter using the 1/2" shaft collar. Secure the shaft collar to the hex adapter using the shaft collar set screw.



Fig. 11

Note: The 1/2" bore shaft collar set screw is specified as follows: 1/8 hex x 1/4-20 x 1/4". Following the specification in order; this means the set screw requires a 1/8" allen key wrench, the nominal screw diameter is 1/4", the thread pitch is 20 threads per inch (tpi) and the screw is 1/4" long."

Mechanical Insight

Throwing Arm Assembly *continued*

Step Three: Counter Weight Arm (*figure 12*)

Necessary Components

Qty.	Description
2	7 hole angles.
2	#10-24 x 3/4" machine screws and washers

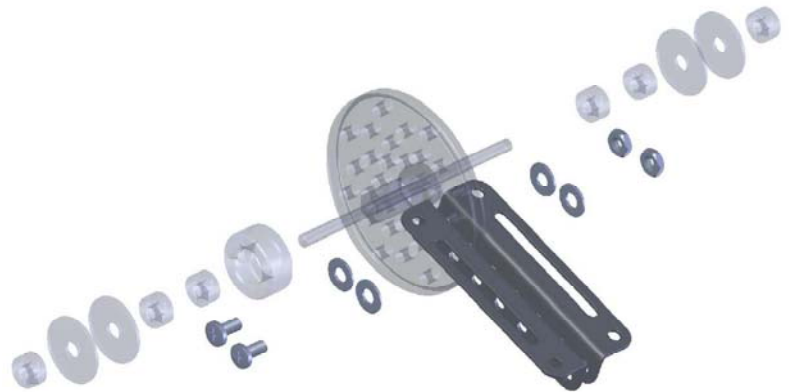

Fig. 12

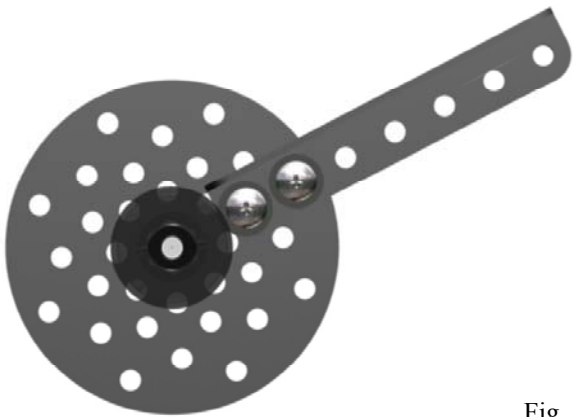

Fig. 13

Procedure

Obtain the necessary components to construct the counter weight arm assembly illustrated in figure 12. Note: An orthographic (front) view of the counter weight arm assembly is shown in figure 13. Use this view to obtain

proper orientation of the throwing arm, 3" wheel and fasteners.

An Engineering Moment: Concentric Circles

Concentric circles share the same centers. The GEARS-IDS™ 3" wheel pictured in figure 14 has sets of 8 holes equally arrayed around four concentric circles.

Approximate layout circles are pictured in the figure 14 illustration.

Create a sketch of the wheel shown in fig. 14. Using dial calipers and a calculator, determine the diameters of the 4 concentric circles on which the holes are arrayed.

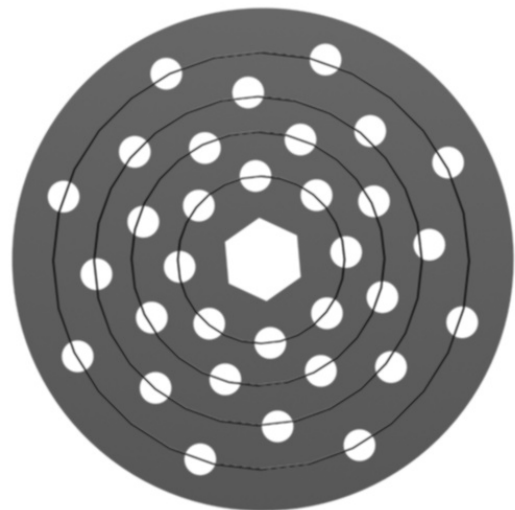

Fig. 14

The sketch should show all dimensions needed to create a SolidWorks model of the wheel. Include both a front (shown) and side view of the 3" wheel in order to provide all the dimensional information needed to model the wheel.

Hint: Since it is impossible to measure from the exact center of the holes, it will be necessary to derive the distance from the center of the wheel to the center of each hole. It is also necessary to know the diameter of the wheel and the diameter of the small holes in order to derive the diameter of the concentric layout circles.

Throwing Arm Assembly

continued

Step Four: Counter Weight Assembly (figure 14)

Necessary Components

Qty. Description

- 1 3/16" x 1-1/2" axle.
- 2 3/16" (bore) shaft collars
- 1 180 degree fish plate
- 4 3/16" flat washers
- 1 #10-24 x 1/2" Phillip head machine screw and nut
- 1 12 ounce lead counter weight

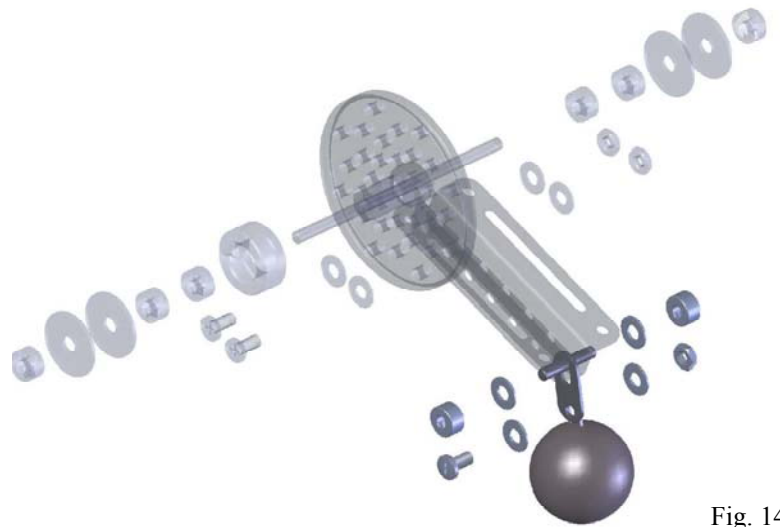

Fig. 14

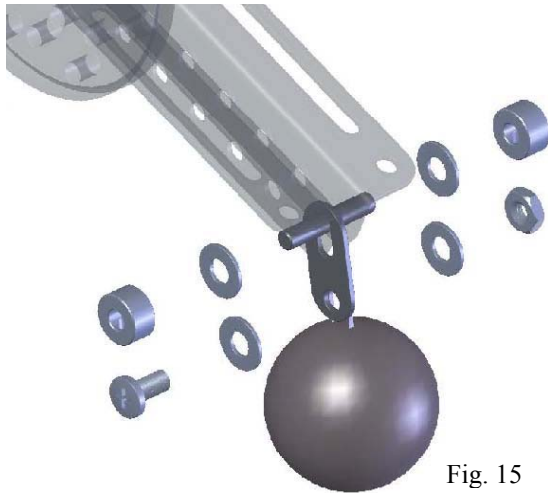

Fig. 15

Procedure

Obtain the necessary components to construct the counter weight assembly illustrated in figure 15.

Connect the fishplate to the lead counter weight using the #6 x 1/2" screw, washers and nut as shown in the illustrations (*Top and left*).

Attach the fishplate and counter weight assembly to the end of the counter weight arm by passing the 1-1/2" axle through the arm members and fishplate. Capture the fishplate inboard between the two 7-hole angles. The fishplate should hang in between the 7-hole angles in such a way as to swing freely through 270 degrees of revolution or more.

Note: Add #10 washers as needed to adjust for side play between the axle and the fishplate.

The fishplate should be firmly affixed to the counter weight so that it cannot move or swing freely.

Note: In order to mount the fishplate to the counter weight, it may be necessary to reconfigure the shape of the brass wire ring on the counter weight. This can be accomplished using a pair of needle nosed pliers and/or a small screwdriver.

A Science Second: Density

The counter weight is a lead sphere measuring approximately 1-1/2" (38mm) in diameter and weighing approximately 12oz. (340g). The average weight density of a homogeneous material can be calculated by the following formula;

$$\text{Density} = \frac{\text{Weight}}{\text{Volume}} = \frac{\text{Weight is pounds}}{\text{Volume is in}^3} \quad \text{Or} \quad \frac{\text{Mass is in grams}}{\text{Volume is in cm}^3}$$

A Science Second: Density continued

Calculating the counterweight density involves these steps;

1. Calculate the volume of the counterweight sphere
2. Determine the weight of the lead sphere in pounds
3. Divide the weight of the lead sphere by the volume of the lead sphere

1.) The volume of a sphere can be calculated using this formula;

$$\text{Volume Sphere} = \frac{4}{3} \pi * r^3$$

The volume of the lead counterweight can be found by making these substitutions;

$$(\text{Pi}) \pi = 3.14 \quad (\text{Radius}) r = 0.75'' \text{ or } 0.062' \text{ of lead sphere.}$$

thus

$$\text{Volume Sphere} = 1.77 \text{in}^3 = 0.001 \text{ft}^3 \quad (\text{Remember: } 1728 \text{ in}^3 = 1 \text{ft}^3)$$

2.) Convert the weight of the sphere from ounces to pounds

Since there are 16 ounces in 1 pound, and the lead sphere weighs 12 ounces the conversion looks like this;

$$\frac{\text{Weight of Sphere in oz}}{16 \text{ Ounces/pound}} = \frac{12 \text{oz}}{16 \text{oz/lb}} = 0.75 \text{lbs}$$

3.) Divide the weight of the lead sphere by the volume of the lead sphere.

$$\text{Density} = \frac{\text{Weight}}{\text{Volume}} = \frac{0.75 \text{lbs}}{0.001 \text{ft}^3} = 750 \text{ lb/ft}^3$$

This value is about 94% correct. Cast lead is actually reported to weigh approximately 708 lbs/ft³. The difference in our calculated weight density may be due to cumulative errors in;

1. Rounding
2. Errors in measurement.
3. Non homogeneous material since we cannot know the purity of the lead material.

Caution: Lead is a dense (heavy) metal. Care should always be taken when handling lead. Always wash your hands after handling lead and never eat food while you are handling lead.

Throwing Arm Assembly

continued

Step Five: Throwing Arm Assembly (figure 16)

Necessary Components

Qty. Description

- 1 5/16 x 18" wood dowel.
- 1 Mast holder with #10-24 set screws
- 2 1/8" hex key set screws 1/4-20 x 1/4"
- 2 #10-25 x 1/2" Phillip head machine screws
- 2 #10 flat washers

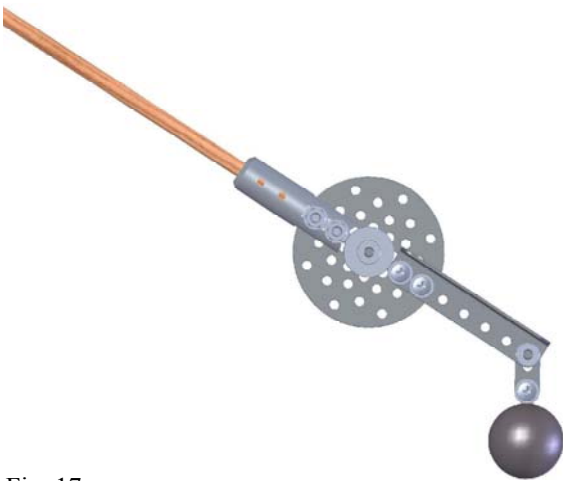

Fig. 17

method is using the GEARS-TrebStar™ simulator to make and test iterative designs in an effort to optimize both the dowel length and the projectile length.

A Science Second: Unbalanced Levers

F2 = 0.032 Newtons

F1 = 3.36 Newtons

D2 = 0.28 Meters

D1 = 0.07 Meters

$$(F1 * D1) - (F2 * D2) = \text{Net Torque}$$

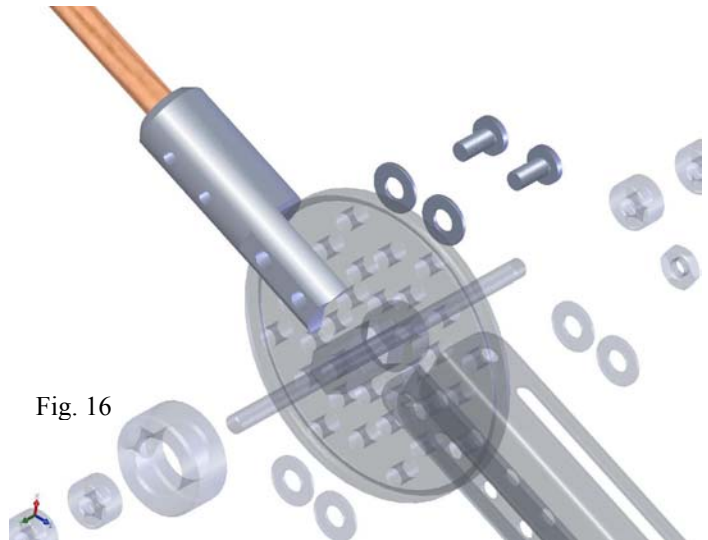
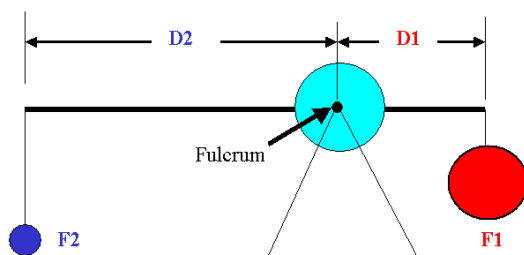

Fig. 16

Procedure

Secure the mast holder to the 3" wheel using 2 #10-24 x 1/2" machine screws and washers as shown in figures 16-17. Hex nuts are not required since the shaft retainer has threaded holes to accept the #10-24 machine screws.

Fasten the 5/16" x 18" wood dowel to the shaft retainer using the #10-24 set screws as shown. The wood dowel has a 1/8" hole drilled in the top. Do not insert the end with the 1/8" hole.

Note: The builder must determine the wood dowel length. There are many ways to optimize the wood dowel length. Trial and error is one method. A better

method is using the GEARS-TrebStar™ simulator to make and test iterative designs in an effort to optimize both the dowel length and the projectile length. Viewed in simplest terms, a trebuchet is an unbalanced lever. In the example to the left, we imagine that the lever arm has no mass (*Thus no weight and no inertia*). Ignoring the lever arm allows us to write a simple mathematical expression to determine the force that causes the arm to rotate about the fulcrum.

On a separate paper, sketch the graphic on the left and use the information provided to determine the following;

1. Net Torque, or net turning force acting to rotate the (*Imaginary*) trebuchet arm about the fulcrum.
2. Direction of rotation of the arm.

Neatness and completeness matter. Remember to record this exercise in your notebook.

Throwing Arm Assembly

continued

Step Six: Throwing Arm Release Pin (figure 18)

Necessary Components

Qty. Description

- 1 Hose clamp
- 1 Paper Clip or 4" length of wire rod

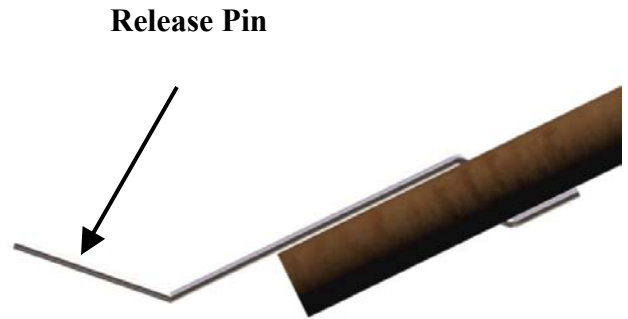

Procedure

Fashion the paper clip or wire rod into the release pin shape pictured in figure 20.

Mount the release pin to the throwing arm by passing the bent wire through the 3/32" hole in the wood dowel. Secure the release pin using the hose clamp as pictured in figure 19.

Note: Trebuchet performance and range can be improved by fastening the release pin to the throwing arm using either duct tape, tie wraps or tightly wound elastic bands instead of the hose clamp. Remember that even a small amount of additional weight at the end of the throwing arm will decrease the net torque produced by the counterweight and reduce the speed and thus range of the projectile.

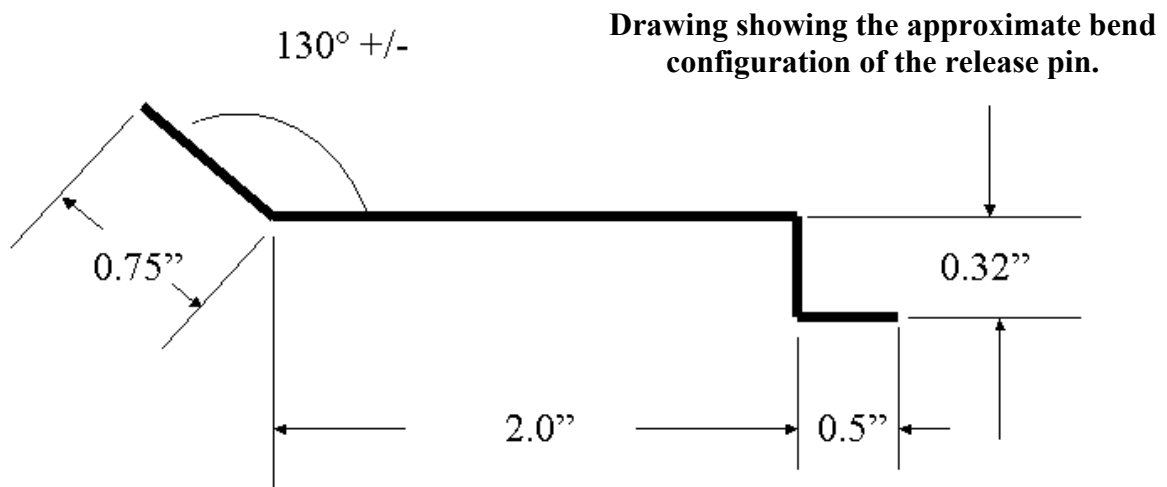

The Sling and Projectile Assembly

Fashion an eye on the end of the sling using a surgeons loop. (shown below)

Surgeon's Loop

1. Make a large loop at the end of the line.
2. Tie a single knot using the loop end.
3. Repeat the single knot one or two more times.
4. Pull tight.
5. Trim the line end close to the knotted loop.

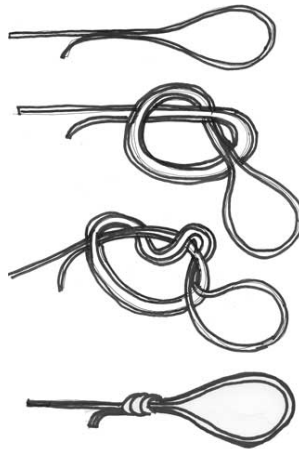

Working End

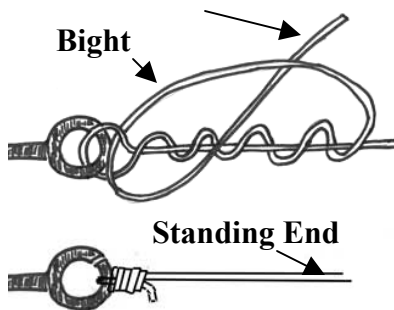

Fisherman's Knot

1. Pass the working end of the line through the swivel eye.
2. Wrap the working end around the standing end 3 or 4 times.
3. Pass the working end through the first loop and back under the bight.
4. Pull tight and trim.

Attach the snap swivel to the sling using a fisherman's knot. (Shown above)

Open the snap swivel hook and pass it through the eye of the cotter pin.

The Cotter pin passes through the hole in the ball and the ends are bent back and flush to the surface.

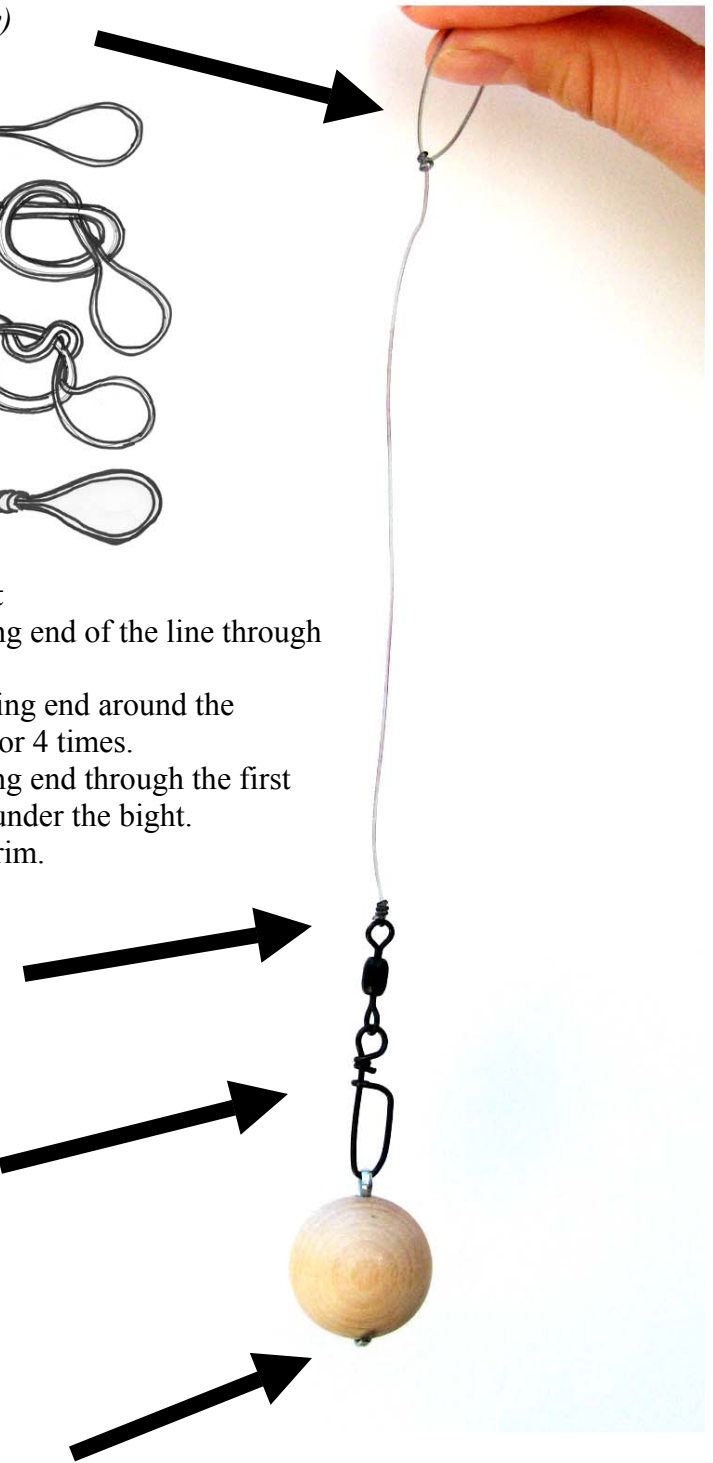

Integrating the Subassemblies

Attaching the Throwing Arm to the Support frames

Step One: Select the axle assembly components from step one. Attach the throwing arm by passing the axle through the top hole in the sine triangle and sliding the fender washers and shaft collars in the order illustrated in figure 21.

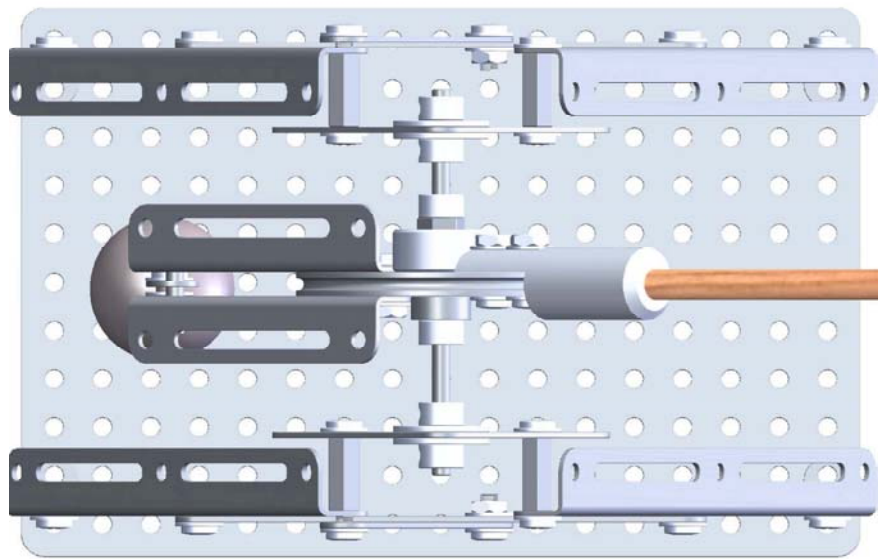

Fig.21 A top view of the axle assembly

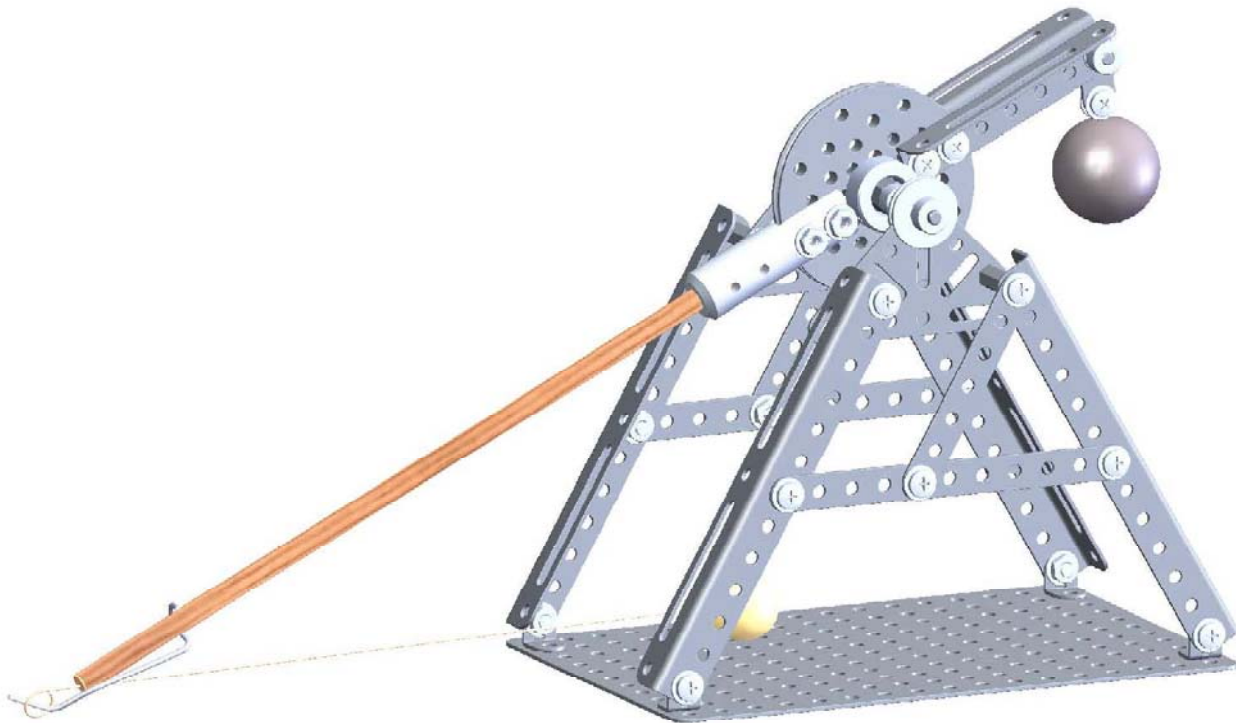

Fig. 22 The completed trebuchet

Hurling: Preparing for Competition

Operating, Testing and Improving Performance

SAFETY FIRST: Always wear safety glasses when you are using the trebuchet. The slip hook on the end of the trebuchet is pointed and it can pose a hazard when it is standing still or while the trebuchet is being used.

Operating the Trebuchet (*Hurling*)

Hurling is a simple matter. Attach the sling and projectile ball to the slip hook on the end of the throwing arm. Pull the throwing arm, sling and projectile to the fully cocked position while holding on to the projectile ball. Hurl the projectile by letting go of the projectile ball while keeping your hand clear of the falling counterweight.

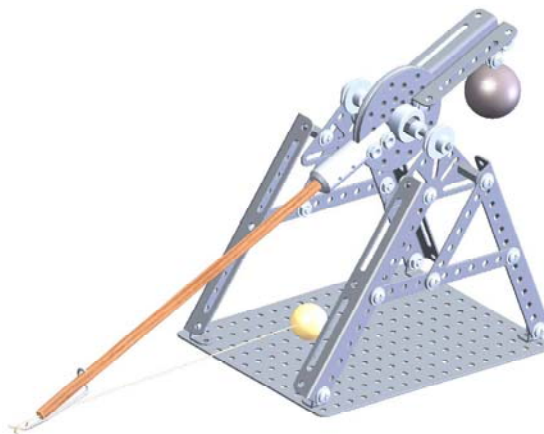

Testing and Improving the Trebuchet

Building the trebuchet described in this text, and hurling the projectile is only the beginning of this engineering exercise. The real challenge posed by this activity is how to improve the range, precision and accuracy of the trebuchet. Specific instructions for how to obtain the best hurling results have been deliberately omitted from these instructions. Careful consideration should be given to factors that affect the range, precision and accuracy of the trebuchet.

Engineering Improvements: Some Good Questions About Trebuchet Performance

The following questions deserve engineering consideration. In some cases the answers may require the design and construction of additional components in order to improve the range, accuracy and precision of a trebuchet. *Example: A projectile slide can increase precision and can be made from oak tag and tape.*

What are the rules of the Totally Trebuchet game? (*Engineers must understand the problem and know the design objective in order to design effective solutions*)

What are the best design considerations and strategies to employ in an attempt to succeed at the game?

What are the relationships between the 8 design parameters, and how do they affect performance?

What is the effect of changing the angle at which the sling and projectile leave the throwing arm?

How does the initial travel or sliding of the projectile ball affect range, accuracy and precision?

What are the benefits of developing a consistent release method and point of release?

Why make the effort to maintain a consistent and repeatable firing position with respect to the target?

How does “play” or looseness in the trebuchet mechanism affect performance?

Assessment: Totally Trebuchet Construction and Use Evaluating Acquired Skills and Competencies

The ability to manage resources and information is an ingredient for success in most careers. The SCANS listed below articulate the skills and competencies necessary for both independent and group achievement. A person without these essential skills and competencies has little to contribute to a team of people whose ultimate success depends on the application of their collective abilities.

Apply Technology	Create	Manage Time
Acquire Data	Design	Appropriate Decisions
Evaluate Data	Provide Leadership	Correct Performance
Access and Use Information	Support Leadership	Improve Systems
Work Cooperatively	Negotiate	Accept Responsibility
Interpret Textual Information	Organizational Skills	Self-management
Interpret Visual Information	Share Knowledge and Skills	Access and Use Resources
Maintain Materials/Equipment	Maintain Files/Records	Trouble Shoot
	Process Information	

A Word About Project Based Learning and Authentic Assessment

Like the medieval trebuchet engineers before them, small teams of students travel the path of discovery by asking and answering relevant questions about the physical principles and mechanics that govern the operation of these machines. The questions they ask, and the ways in which they attempt to develop answers provide authentic opportunities to construct new knowledge. The build report or engineering notebook is an excellent way for students to document and present what they know and are able to do. The build report also provides the evidence necessary to assess the results of their journey of discovery.

Project based learning provides opportunities for students and teachers to construct competencies and skill sets through a process of inquiry and discovery. The skills, knowledge and experiences acquired through participating in project-based learning activities depends in part on:

- The participants' ability and desire to frame relevant questions and by the reward and satisfaction they derive from the answers they construct.
- The demands and expectations of the coursework

Carefully designed projects, products and activities include opportunities for: *authentic learning, acquisition of central concepts, motivation and interest, using essential tools and developing essential skills, multiplicity of solutions, performance based assessment, collaboration.*

The assessment rubric on the following page is calibrated to measure the degree to which participating students take advantage of the opportunities presented in the Totally Trebuchet construction activity.

Assessment Rubric: Totally Trebuchet Construction

This rubric is offered as an example. Teachers and students are encouraged to create assessment tools that reflect their needs and expectations.

Required Skill or Competency	Meets or Exceeds this Requirement Score 4-5 pts	Meets Some of this Requirement Score 2-3 pts	Meets little or None of this Requirement Score 0-1 pts
Successfully constructs the working trebuchet by following the example described in the text and illustrations provided.			
Demonstrates organization and management skills and uses the tools and materials responsibly.			
Participates in an effort to operate, test and improve the range and precision of a working trebuchet.			
Can accurately measure and record the 8 design parameters.			
Produces clearly labeled sketches detailing the trebuchet components and dimensions.			
Creates solid models, working drawings and assemblies of the trebuchet components and subassemblies.			
Records the experimental methods used to improve the range and accuracy of the trebuchet.			
Constructs a trebuchet capable of hurling a 1” diameter wood ball a distance of 20’ into a 20” target circle 5 consecutive times.			