

GEARS-Pittman Competition Motor

Size and Mounting Information

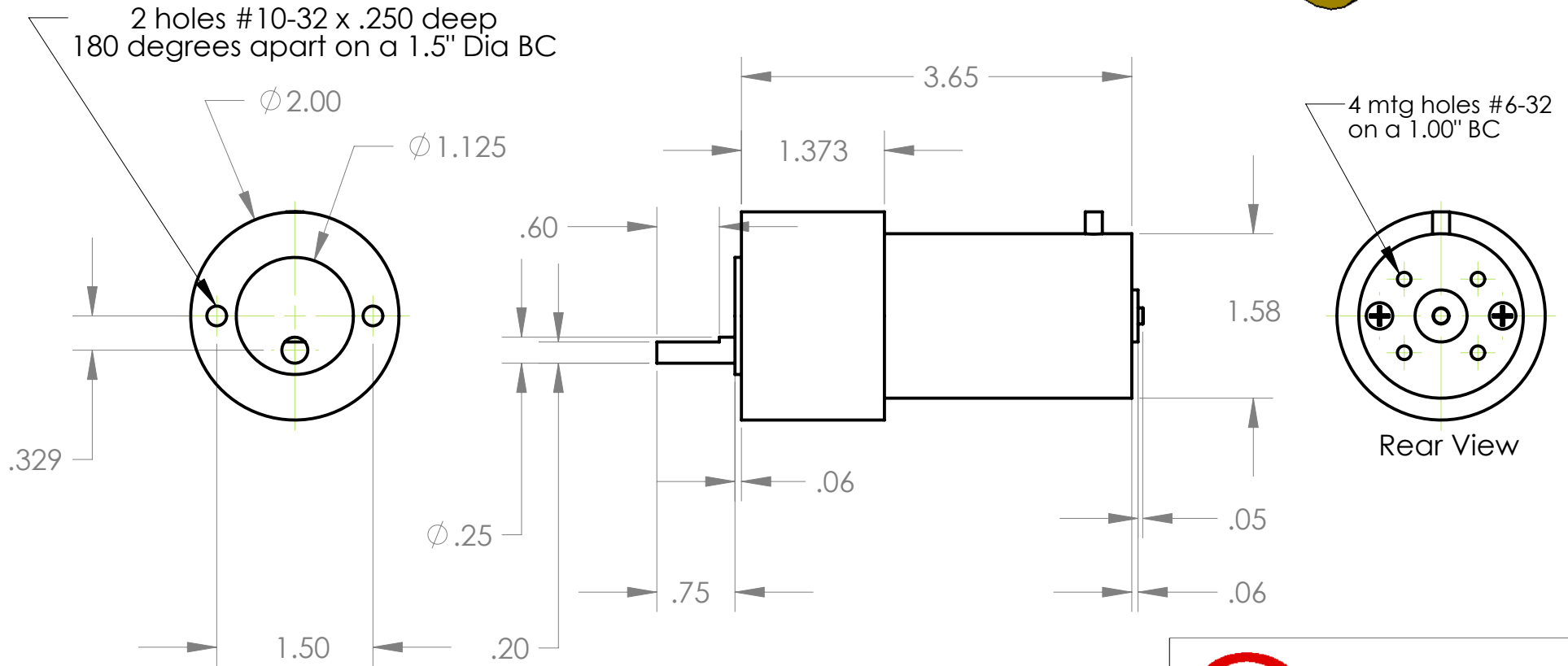
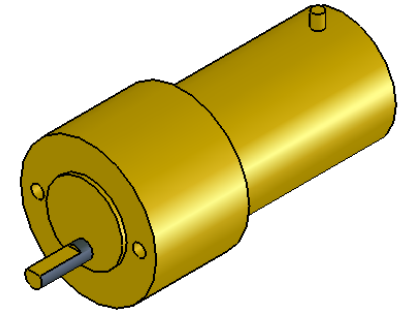

Property of:
GEARS Educational Systems
105 Webster Street
Hanover, MA 02360
Drawn by:
Michael Bastoni

Gears
Educational Systems, LLC

| | | |
|------------------|--------------------------------------|-----------------|
| SIZE A | DWG. NO. Competition Motor | REV 1 |
| SCALE: 1:2 | WEIGHT: | SHEET 1 OF 1 |